

SECURITRON MODEL MUNL-12, MUNL-24 MORTISE UNLATCH INSTALLATION AND OPERATING INSTRUCTIONS

1. DESCRIPTION

Securiton's Mortise UnLatch is a revolutionary new type of electric strike which **eliminates the necessity to perform a routing operation on the door frame for installation**. The **motor driven Mortise UnLatch** also presents a **fully concealed appearance** on the door which not only enhances architectural appeal but **improves security** over a conventional electric strike as an intruder is less able to determine the type of security device present on the door. The Mortise UnLatch **functions with all North American mortise locks** and includes a **latch status output** which reports when the door is in latched (secure) condition or is open.

Product Specifications are: **Input Voltages:** 12 VDC (MUNL-12), +20%, -10%. 24 VDC (MUNL-24), +20%, -10%. **Current:** At rest: 40 mA (either voltage). When operating- 4 Amp input surge @ 12 VDC; 2 Amp input surge @24 VDC for 100 milliseconds and 600 mA @ 12 VDC or 300 mA @ 24 VDC during motor movement. **Operating Temperature:** -10° to 125° F.

FIG 1: MORTISE UNLATCH DIMENSIONS (INCHES)

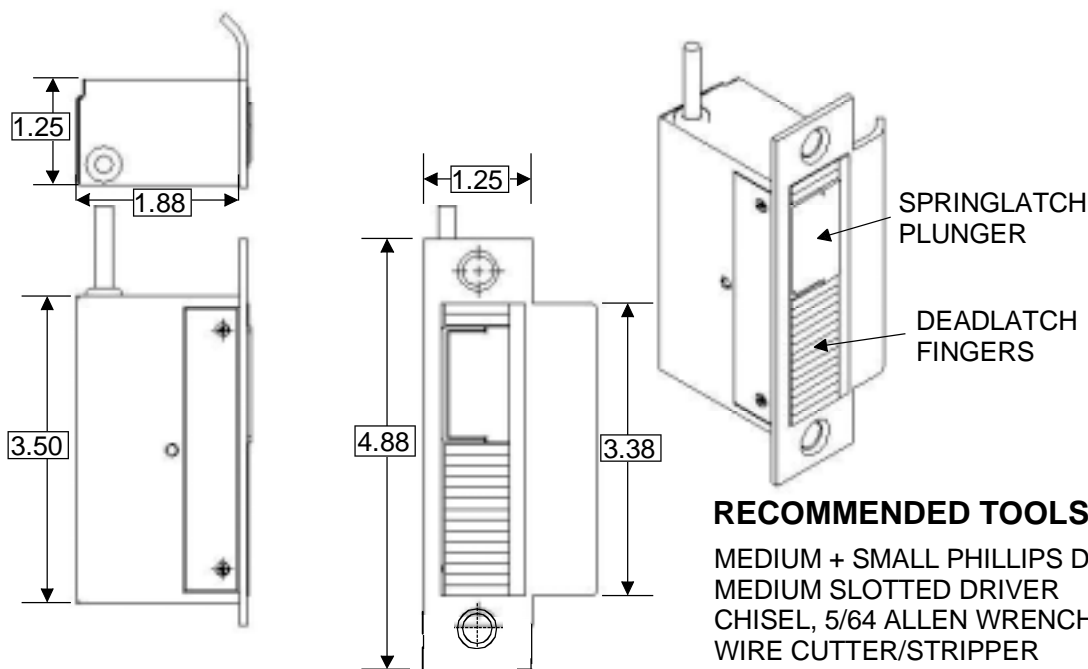

RECOMMENDED TOOLS

- MEDIUM + SMALL PHILLIPS DRIVER
- MEDIUM SLOTTED DRIVER
- CHISEL, 5/64 ALLEN WRENCH
- WIRE CUTTER/STRIPPER
- VOLT/OHM METER
- CRIMP CONNECTORS
- CRIMP PLIERS

2. PHYSICAL INSTALLATION

2.1 SURVEY

The installer must first be sure that the **latch is of the mortise type** (see the drawing to the right.) A mortise lock (or latch) includes a square shaped springlatch and a "pin" called the deadlatch pin or guard bolt which may be positioned either above or below the springlatch. Most **mortise panic bar latches** are also perfectly compatible with the MUNL. **Note, however, that if the mortise lock assembly includes a dead bolt**, the dead bolt will not be operable. The most common **alternate type of latch** in use in North America is called **cylindrical, tubular or bored**. The standard UnLatch (model numbers UNL-12 and UNL-24) is designed for this alternate type of latch. Securiton does not offer an UnLatch solution for a rim latch (rim latches are on the surface of the door rather than being mortised into the middle of the door).

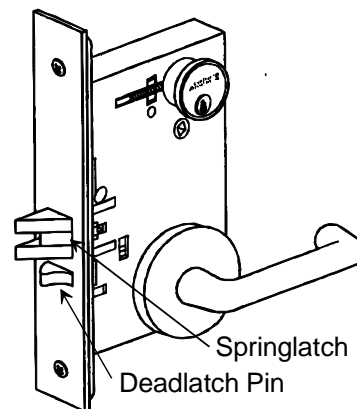

2.2 HOLLOW METAL (STEEL) FRAME MOUNTING

Remove the existing ANSI 4 7/8" strike plate (it will be discarded) and experimentally try to fit the Mortise UnLatch in the resulting cavity. In some cases the cavity will be large enough to accommodate the Mortise UnLatch and you will have nothing to do but pull the wires up the hollow door frame and screw the Mortise UnLatch into place. In other cases you will find a "**dust box**" within the frame that will get in the way of the Mortise UnLatch. The dust box must be cleared away to make room. Generally, a sabre saw, dremel tool or a drill with a fly cutting bit is the most effective tool to do this. You can also find that the edge of the dry wall panel interferes with the Mortise UnLatch. Simply chip away some of the dry wall with a screwdriver. Once you are able to fit the Mortise UnLatch into the frame, **vacuum out any concrete dust and metal shavings** (these can work their way into the UnLatch mechanism and cause problems) and **loosely mount it and proceed to Section 2.4**, adjusting for latch/deadlatch location. **Note that the face of the Mortise UnLatch is protected by a removable film.** Leave this on during the "pre-mounting" so as to preserve the metal finish against scratching and to block the possible entry into the mechanism of dust or metal shavings. Remove the film when you adjust the unit for latch/deadlatch location (Section 2.4).

2.3 WOOD FRAME MOUNTING

For installation in a wood frame use a chisel to create a space for the Mortise UnLatch behind the existing strike. Remove the strike and place the **template** (last page of this manual) on the door (registering it to the strike mounting holes). This will show you the space that must be chiseled out. As you get close to finishing the chiseling job, experimentally try to fit the body of the Mortise UnLatch in the cavity. This will avoid chiseling too big a space. A **tight fit is preferred** as it helps the solidity of the mounting. Normally, with a wood frame, the wires will be run inside the wall. Simply drill from the back of the cavity you have created rearward into the wall space to admit the wires. To mount the Mortise UnLatch to the wood frame, use the two #12 x 1" furnished flat head wood screws. Once you are able to fit the Mortise UnLatch into the frame, **vacuum out any wood dust and metal shavings** (these can work their way into the UnLatch mechanism and cause problems) and **loosely mount it and proceed to Section 2.4**, adjusting for latch/deadlatch location. **Note that the face of the Mortise UnLatch is protected by a removable film.** Leave this on during the "pre-mounting" so as to preserve the metal finish against scratching and to block the possible entry into the mechanism of dust or metal shavings. Remove the film when you adjust the unit for latch/deadlatch location (Section 2.4).

2.4 ADJUSTING FOR LATCH/DEADLATCH LOCATION

One of the remarkable features of the Mortise UnLatch is that it **adjusts to suit different models of North American mortise locks**. With conventional electric strikes, the strike model typically needs to be matched to the lock/latch model and this complicates sourcing the electric strike. There is **one known exception: Sargent model 7800 or 8200 in retrofit** (the lock is already present). The Sargent lock can not normally be accommodated because its springlatch and deadlatch pin are positioned so close to the bottom of the opening. To employ the Mortise UnLatch with Sargent, **purchase the accessory tab kit, model #STK-1**. These new mounting tabs sufficiently reposition the Mortise UnLatch to make it work with the Sargent Lock. Note that **in new construction**, when the door and frame have been specifically prepared for the Mortise UnLatch and Sargent 7800/8200, **the accessory tab kit is not needed**.

Adjustment of the Mortise UnLatch is necessary because different lock manufacturers vertically position both the springlatch and deadlatch pin in widely differing locations along the lock body. The Mortise UnLatch accommodates this by allowing positional adjustment of its **springlatch plunger** (the component which pushes in the springlatch) and then operating the deadlatch pin through moving "**deadlatch fingers**" which fill the rest of the strike opening.

The adjustment procedure is accomplished in two logical steps. **First you must determine the position of the springlatch plunger and then perform the adjustment to set that position.**

2.4.1 DETERMINING SPRINGLATCH PLUNGER LOCATION

The goal of this determination is to **vertically align the Mortise UnLatch's springlatch plunger with the lock's springlatch**. The deadlatch pin will then be "automatically" operated by the deadlatch fingers regardless of its position on the lock. It's important, however, to determine the position in such a way that maximum tolerance is achieved in the event that the door shifts against the frame.

To begin, loosely mount the Mortise UnLatch and close the door so that you can see the top and bottom of the lock's springlatch. Draw lines on the lip of the Mortise UnLatch's strike which correspond to the lock's springlatch position. Next dismount the Mortise UnLatch. The drawn

lines and knowledge of the gap between the springlatch and deadlatch pin are used to determine the vertical position of the springlatch plunger. When **this gap is greater than 1/4"**, best reliability is obtained when the springlatch plunger position is centered on the springlatch. **When the gap is smaller than 1/4"**, however, simply centering the springlatch plunger risks positioning the deadlatch pin too close to the springlatch plunger so the procedure is to position the edge of the springlatch plunger midway between the springlatch and deadlatch pin. Figure 2 illustrates these points.

FIG. 2: DETERMINING POSITION OF SPRINGLATCH PLUNGER

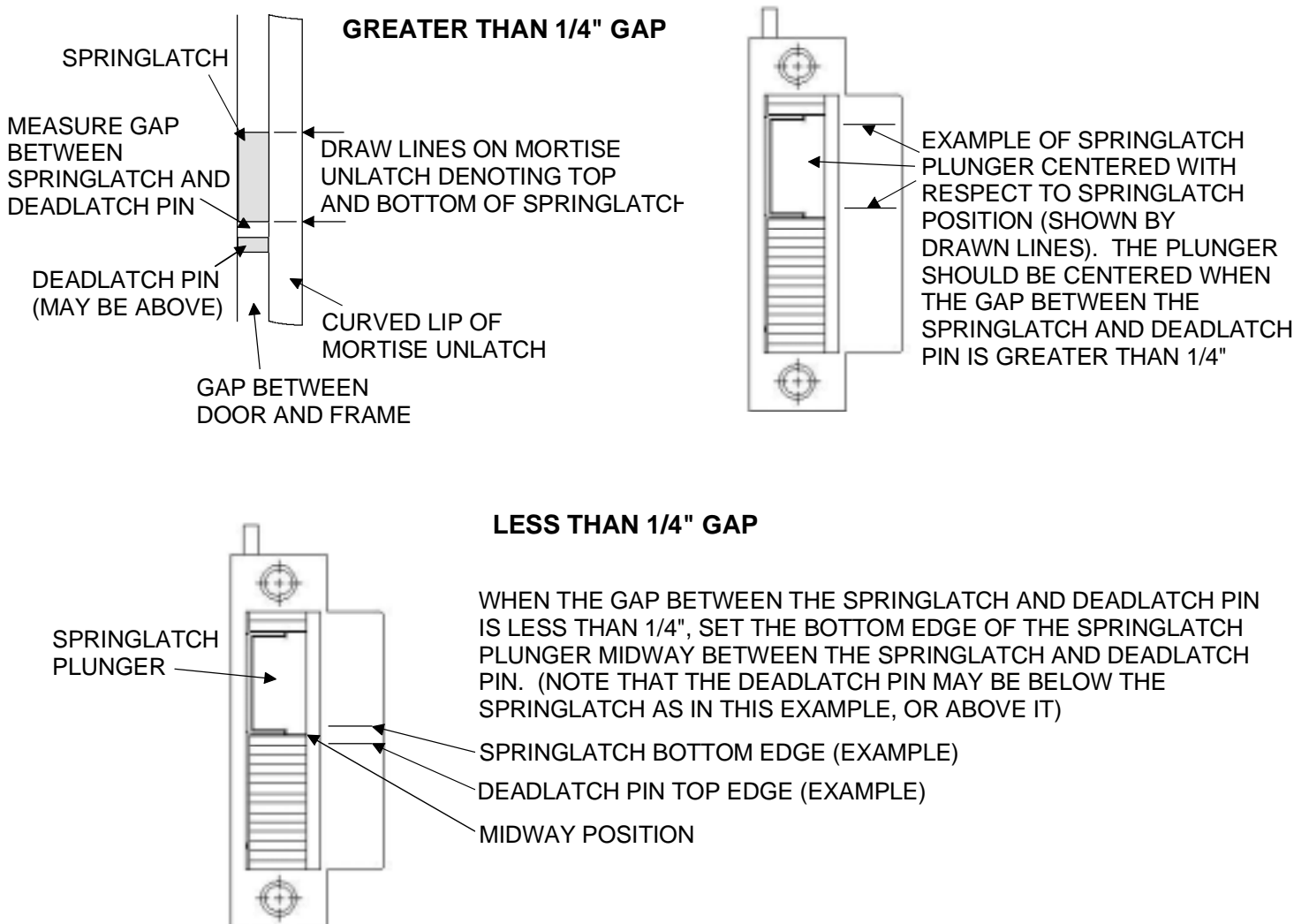

2.4.2 ADJUSTING SPRINGLATCH POSITION

Now that you have marked the unit with the correct position for the springlatch plunger, the actual adjustment must be performed. Figure 3 shows the procedure.

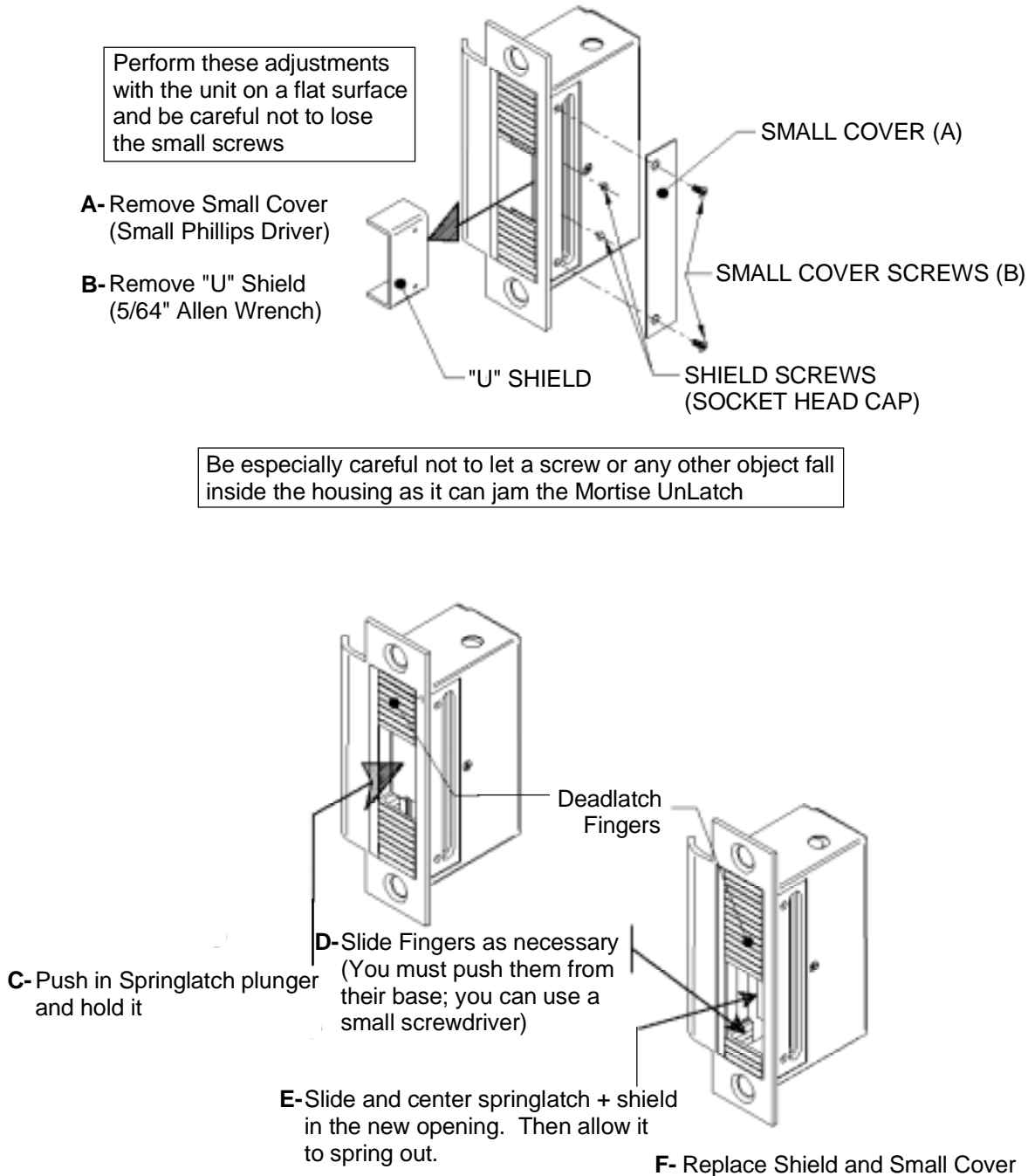
FIG. 3: ADJUSTING SPRINGLATCH POSITION

2.5 FINAL ADJUSTMENT WITH SPACERS

For reliable operation, the door needs to close so that the latch easily enters and is retained by the Mortise UnLatch. The door should not have to be pushed to engage as can be the case with a poorly fitting or poorly closing door. To check this point, when the Mortise UnLatch has been mounted, after the door is closed and latched, you should be able to “rattle” the latch against the Mortise UnLatch plunger by pushing the door in and out. **The amount of movement in the door latch should be about 1/16-1/8” (1.5-3MM).**

If the amount of slack or rattling is greater than 1/16-1/8”, you need the door to “close earlier”. In effect, the edge of the stop needs to be closer to the Mortise UnLatch. To adjust for this, first check to see if the stop has “silencers” on it. These are cylindrical rubber bumpers which quiet the noise of a closing door but also have the effect of making the door close earlier. If you have silencers and the door is still rattling too much, contact the factory for additional door stop spacers (the Mortise UnLatch is shipped with two). If you don’t have silencers, add one or two door stop spacers as is shown in Figure 4 to cause the door to close earlier.

If the amount of slack or rattling is less than $1/16-1/8$ ", you have a "tight" door and the ability of the door to close and latch reliably is in question. To adjust for this, first check to see if the stop has "silencers" on it. These are cylindrical rubber bumpers which quiet the noise of a closing door but also have the effect of making the door close earlier. Remove the silencers (they pull out) and this will add slack to the closed position of the door. Be sure to check the entire length of the door for the silencers. If the door has no silencers and is still tight in latching, a locksmith should be engaged to readjust the door so that it closes properly or the installation will not be reliable.

Figure 4 illustrates the points made in this Section.

FIG. 4: FINAL ADJUSTMENT OF DOOR CLOSING TOLERANCE

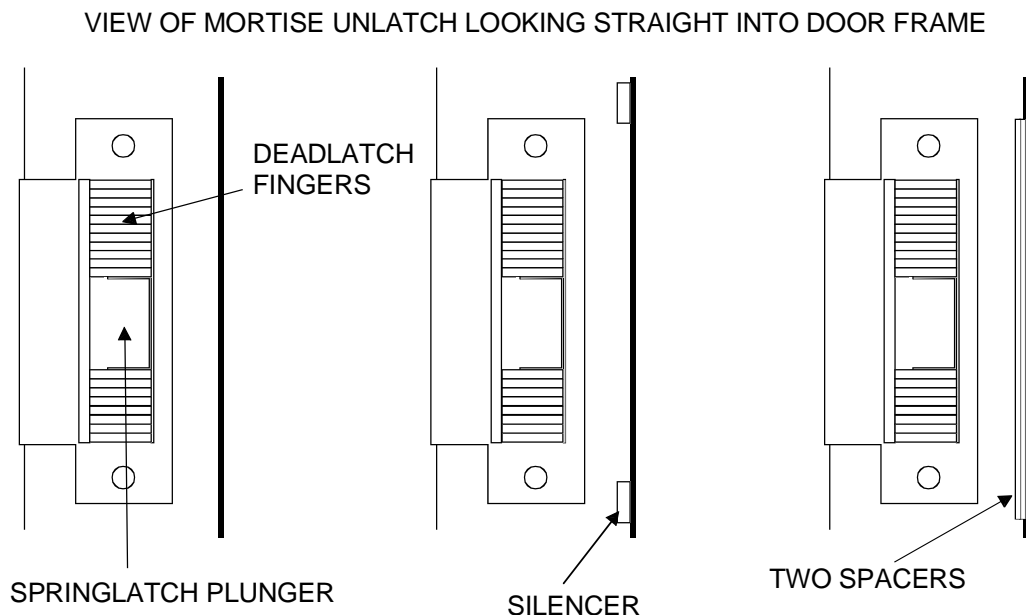

3. OPERATION

While you can make a successful installation without knowing how the Mortise UnLatch functions, it's best if you understand its operation in the event you run into difficulties or questions. The operation of the Mortise UnLatch is, of course, intimately connected with the way mortise locks work on a door so we'll cover this first.

Mortise locks are the highest quality and heaviest duty locks for sale in North America. They not only provide long operating life but deliver the highest level of physical security obtainable in a mechanical latch. To assure this security, all mortise locks include **deadlatching** function. This means that when the door is closed and latched, a deadlatch pin, present on the lock face, is pressed in. This **mechanically pins the springlatch** so that it cannot be moved by an object (such as a credit card) which is pushed in between the door and frame.

In order to release the mortise latch, the Mortise UnLatch has two moving elements under the control of a motor. We call these the **springlatch plunger and deadlatch fingers**. When the door is in the closed and secure position, the springlatch pushes in the springlatch plunger and the deadlatch pin rests on the deadlatch fingers which push in the deadlatch pin. This maintains the latch in the secure position and makes full use of the deadlatching function.

When the Mortise UnLatch operates (the trigger wire connects to the +V wire), the deadlatch fingers retract into the body of the Mortise UnLatch which allows the deadlatch pin to move out. Then the springlatch plunger and deadlatch fingers simultaneously push the latch and deadlatch pin back into the lock body and the door may be opened from the outside. This operation takes about $1/3$ of a second. When the trigger wire is removed from the +V wire, the Mortise UnLatch will return to its initial condition: the springlatch plunger will retract into the Mortise UnLatch body which allows the latch to resecure the door and the deadlatch fingers will push out depressing the deadlatch pin and freezing the latch for best security.

FIG 5: MORTISE UNLATCH SIDE VIEW IN REST (SECURE) POSITION

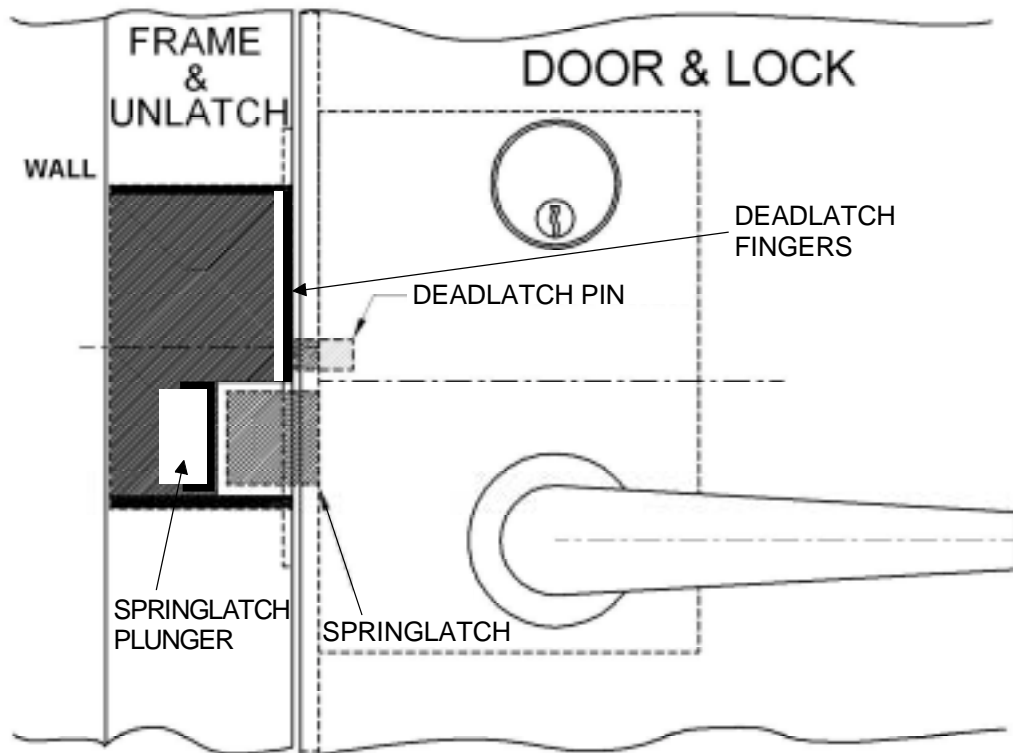

IN THE REST (SECURE) POSITION, THE SPRINGLATCH IS ALLOWED TO COME OUT BY THE SPRINGLATCH PLUNGER THEREBY SECURING THE DOOR. THE DEADLATCH FINGERS, HOWEVER, PUSH IN THE DEADLATCH PIN WHICH "FREEZES" THE SPRINGLATCH FOR BEST SECURITY.

FIG 6: MORTISE UNLATCH IN OPERATION

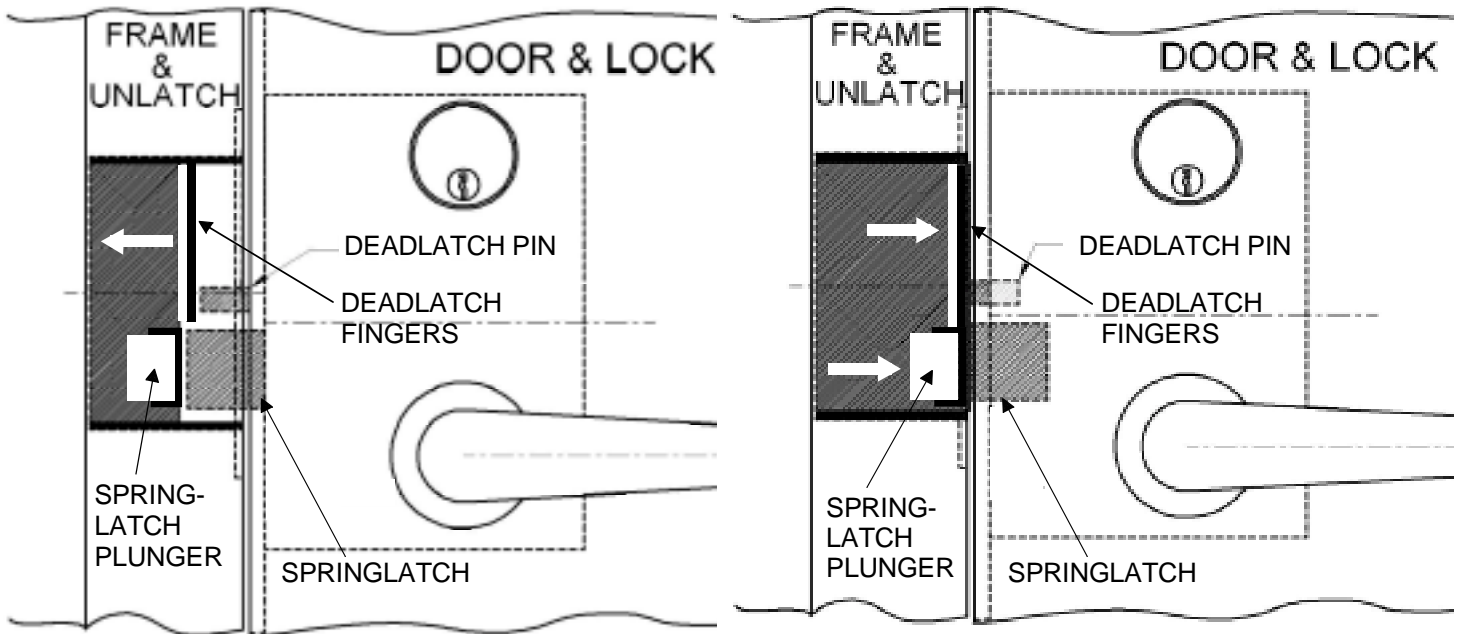

IN THE FIRST OPERATIONAL STEP, THE DEADLATCH FINGERS WITHDRAW WHICH ALLOWS THE DEADLATCH PIN TO COME OUT. THIS "UNFREEZES" THE SPRINGLATCH

FINALLY, BOTH THE DEADLATCH FINGERS AND THE SPRINGLATCH PLUNGER MOVE FORWARD TOGETHER. THIS PUSHES OUT THE SPRINGLATCH AND DEADLATCH PIN AND THEREBY RELEASES THE DOOR

Note that if the door is heavily **pre-loaded** (by someone trying to pull it open before the Mortise UnLatch has released it for example), the Mortise UnLatch may not possess enough power to release the door. This is termed a **stall condition** for the motor. When a motor is stalled for a period of time, it can be damaged by heat build up as motors draw heavy current when they're not permitted to move. The **Mortise UnLatch automatically detects any stall condition** that persists for more than 1.5 seconds and shuts itself off. To operate, the Mortise UnLatch must simply be triggered again (which is the normal action for anyone who has failed to enter).

4. WIRING

4.1 GENERAL ELECTRICAL CHARACTERISTICS

The Mortise UnLatch is a six wire device. Power (12 or 24VDC depending on the model) is applied to the red and black wires observing polarity and **power should be continuously present on these wires**. **If you connect power in reverse, the Mortise UnLatch will not operate but it will be damaged if left connected for an extended period of time.** To operate the Mortise UnLatch, the **trigger wire (orange)** is connected to the **red wire (+V)** via an external switch. When this connection is made, the Mortise UnLatch will release the door and keep it released so long as the red and orange wires are connected. When connection between these wires is broken, the door will be resecured (once it recloses). In certain applications the door is released all day and secured all night. There is no problem operating the Mortise UnLatch in this manner (continuous duty) but it is more common for the door to be released for only a few seconds at a time for controlled entry. This is typically done by relay contacts which close from an external card reader, digital keypad or keyswitch. The external control device includes a timing function which will operate the Mortise UnLatch for a few seconds to permit each entry. Like most conventional electric strikes, the Mortise UnLatch is **fail secure** which means that it will maintain the door in a secure position if power is lost. Entry is not possible (except with a key) but people can, of course, exit by simply turning the door handle or knob from the inside.

FIG. 7: MORTISE UNLATCH WIRING

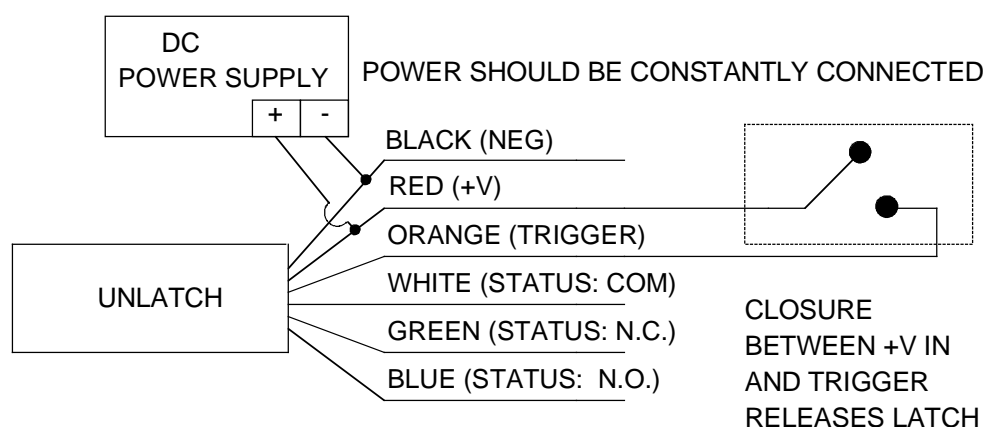

In normal operation, the Mortise UnLatch draws about 600 mA @ 12 VDC or 300 mA @ 24VDC when it operates (the plungers are moving) and a steady 40 mA at all times. Note that regulated input voltage is not required to operate the Mortise UnLatch. **Full wave rectified DC is acceptable** (transformer + bridge rectifier). **Power supply surge capacity**, however, is ideally 4 Amps @ 12 VDC or 2 Amps @ 24 VDC for best operation. This is because the Mortise UnLatch's motor (like all motors) will momentarily draw a lot more current if it has to "work harder". This occurs for a very short time at motor start. If power supply surge capacity is limited, the Mortise UnLatch will still operate, but more slowly. The same condition of high current draw will occur for a longer period of time if the latch is binding which could be a permanent condition of the latch or could be because the person trying to enter is pulling on the door. Again, the Mortise UnLatch will function but more slowly and weakly. If a full capacity power supply is not practical, a 1 Amp power supply which includes battery backup such as Securitron's model BPS-12-1 or BPS-24-1 (with battery) is an equally effective device to power the Mortise UnLatch as the battery will provide extra surge current as it is needed. Another point to note is that when one **relatively large power supply is serving a number** of Mortise

UnLatches, the extra current capability will always be there as each unit will operate at different times so each can draw extra current from the power supply when needed.

If you are using a smaller capacity power source, you may be satisfied with the operation of the Mortise UnLatch since the reduction in torque is only noticeable when the door is pre-loaded. There is, however, an important electronic effect. During the brief moment while the motor is starting to move, the Mortise UnLatch will “try” to draw 4 or 2 Amps (depending on the voltage). A power supply of lower capacity will react to this condition by sharply dropping its voltage for the same period. While this will not harm the power supply, it may “crash” microprocessor equipped devices like digital keypads (such as Securitron’s model DK-11 or DK-26) that are being **operated from the same power supply**. If, therefore, your installation includes a digital keypad, or other microprocessor equipped device, make sure you have full power supply capacity (or a smaller supply with battery backup) or use a separate power supply for the keypad or other device.

4.2 WIRE GAUGE SIZING

If the power supply is **some distance from the lock, voltage will be lost (dropped)** in the connecting wires so that the Mortise UnLatch will not receive full voltage. The amount of voltage that is dropped in the wires depends on the resistance of the “round trip” wire run compared to the resistance of the Mortise UnLatch. The issue is complicated by the fact that the resistance of the Mortise UnLatch is 20 Ohms @ 12 VDC or 80 Ohms @ 24 VDC when it is operating (the motor is moving) but the resistance drops as low as 3 Ohms @ 12 VDC or 12 Ohms @ 24 VDC for 100 milliseconds just as the motor starts. If the unit is denied full voltage during this motor start period, it will operate but with less torque so it will not release the latch as crisply when the latch has pre-load on it. **Selecting thick wires to power the Mortise UnLatch will maintain strong torque even during start up.** The following table shows distances from the Mortise UnLatch to the power source and calls out the wire gauge needed to **fully** maintain torque. Note that if your installation requires the power source to be more distant or has other complications, the factory can assist you.

Distance (one way)	50 ft. (15 M)	100 ft. (30 M)	200 ft. (60 M)
Wire Gauge for UNL-12	16	14	12
Wire Gauge for UNL-24	22	20	18

4.3 LATCH STATUS SENSING

The Mortise UnLatch includes a latch status sensing feature. When the door is closed and the door latch has engaged the Mortise UnLatch (specifically the springlatch plunger has been pushed in by the door latch), the Mortise UnLatch will **report this secure condition** by outputting a closed circuit condition between the white (COM) and green wires (see the drawing to the right). When the **door is not securely latched**, the closure will be between the white and blue wires. This dry SPDT output can carry **1 Amp @ 30 VDC maximum**. This signal is normally connected to the building alarm system and it provides superior information compared to conventional door contacts which show only that the door is closed, not whether it is latched. Note that the Mortise UnLatch’s ability to report on the latched status of the door **depends on it receiving constant power**. Any time power is cut to the Mortise UnLatch, it will report the door as secure regardless of whether it is latched or not.

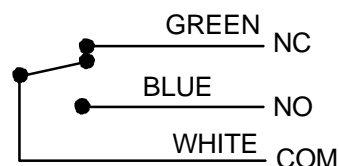

The Mortise UnLatch uses the information as to whether the door is latched or not for a second purpose. The **Mortise UnLatch will not operate unless the latch is in the secure position** (the springlatch plunger is pushed in). Operationally, the door can be opened anyway (it is not latched) so there is no benefit to the end user from the Mortise UnLatch operating unless the door is latched. Inhibiting operation when the door is not properly closed and latched also helps protect the Mortise UnLatch against operating its motor into some jam condition in the event of severe misalignment of the door.

MAGNACARE LIMITED LIFETIME WARRANTY

SECURITRON MAGNALOCK CORPORATION warrants that it will replace at customer's request, at any time for any reason, products manufactured and branded by SECURITRON.

SECURITRON will use its best efforts to ship a replacement product by next day air freight at no cost to the customer within 24 hours of SECURITRON's receipt of the product from customer. If the customer has an account with SECURITRON or a valid credit card, the customer may order an advance replacement product, whereby SECURITRON will charge the customer's account for the price of the product plus next day air freight, and will credit back to the customer the full amount of the charge, including outbound freight, upon SECURITRON's receipt of the original product from the customer.

SECURITRON's sole and exclusive liability, and customer's sole remedy, is limited to the replacement of the SECURITRON product when delivered to SECURITRON's facility (freight and insurance charges prepaid by customer). The replacement, at SECURITRON's sole option, may be the identical item or a newer unit which serves as a functional replacement. In the event that the product type has become obsolete in SECURITRON's product line, this MAGNACARE warranty will not apply. This MAGNACARE warranty also does not apply to custom, built to order, or non-catalog items, items made by others (such as batteries), returns for payment, distributor stock reductions, returns seeking replacement with anything other than the identical product, or products installed outside of the United States or Canada. This MAGNACARE warranty also does not apply to removal or installation costs.

SECURITRON will not be liable to the purchaser, the customer or anyone else for incidental or consequential damages arising from any defect in, or malfunction of, its products. SECURITRON does not assume any responsibility for damage or injury to person or property due to improper care, storage, handling, abuse, misuse, or an act of God.

EXCEPT AS STATED ABOVE, SECURITRON MAKES NO WARRANTIES, EITHER EXPRESS OR IMPLIED, AS TO ANY MATTER WHATSOEVER, INCLUDING WITHOUT LIMITATION THE CONDITION OF ITS PRODUCTS, THEIR MERCHANTABILITY OR FITNESS FOR ANY PARTICULAR PURPOSE.

APPENDIX A: TROUBLESHOOTING

PROBLEM-- Unit will not operate when trigger wire is connected to +V.

On a new installation, make sure that DC power (12 or 24 volts depending on the model) is connected to the red and black wires with correct polarity. When this is confirmed, note that the Mortise UnLatch will never operate unless the springlatch plunger is pushed in by the springlatch (see Section 3.3). You can be “fooled” by this feature if you’re trying to test operate the Mortise UnLatch with the door open. To do this, use a pencil or other similar object to lightly push in the springlatch plunger and then close the trigger wire to +V and you will see the Mortise UnLatch plungers move.

On a service call for a unit with successful operating history, in addition to the checks mentioned above, check to see if the door and latch have gotten into a warped situation where there is heavy pre-loading on the door. The Mortise UnLatch’s motor may not be able to release the latch under this condition but you should be able to hear it trying to release the latch. The Mortise UnLatch will automatically shut down its motor if it can’t release the latch within 1.5 seconds. It will operate normally when it is re-triggered. You should be able to try operation by removing the pre-loading by pushing the door closed with enough force to counteract the pre-loading. Note that this situation is more likely if power supply capacity is less than 2 or 4 Amps (see Section 3.1). Corrections for this type of warped door situation is to have the door serviced and possibly increase the capacity of the power supply.

If the unit still will not function, note that it does have an internal microprocessor that could have gotten into a crash condition. This can happen some times if the unit is under-powered (see Section 3.1) and has consequently stalled (the motor is not receiving enough power to operate the latch). While the motor is in the process of stalling, voltage to the processor will sharply drop and this can crash the microprocessor. A crash can also occur as a random event but this is unusual. The **recovery technique** is to de-power the unit, and then re-power it **with the red and orange wires already connected** (both then connect to +V). This re-initializes the firmware. Naturally, once this operation has been performed, return the unit to standard wiring (orange only connects to +V to trigger the unit.)

Finally, the unit could have experienced motor failure or other internal electronic failure. It is repairable by the factory.

PROBLEM -- Unit will occasionally not operate.

Generally, this comes from too much door pre-loading possibly coupled with a low capacity power source. When the Mortise UnLatch can’t generate enough torque to release the latch, it automatically shuts down but then operates the next time it is triggered. See the previous paragraph.

PROBLEM -- Latch does not re-secure when the door re-closes.

This is not a problem with the Mortise UnLatch but is rather a problem with the installation. The latch is simply not moving into position. Make sure the door closer is properly operating to re-close the door with reasonable force. Next, re-read Section 2.5 to make sure the Mortise UnLatch is in the correct position with respect to the door stop.

PROBLEM -- Latch status sensing does not function.

The latch status output contacts (see Section 3.3) will change state when the springlatch plunger is pushed in. To check this, therefore, push the springlatch plunger lightly in with a pencil or other similar object. Make sure the unit is receiving power when you make this check or the output contacts will not switch. If they still do not switch, the unit will need to be returned to the factory for repair.

PATENTS

The Mortise UnLatch is covered under U.S. patents #5,474,342 and #6,022,056 with other US and international patents pending.

TEMPLATE FOR CHISELING OUT A WOOD FRAME

